

A-A (1:2)

12 P9 $\begin{pmatrix} -0,018 \\ -0,061 \end{pmatrix}$



Schraubenkompressor
SKL 1200 C

Maßblatt - Dimension sheet

Index Revision Nr.

910 250-00 M

Name Datum

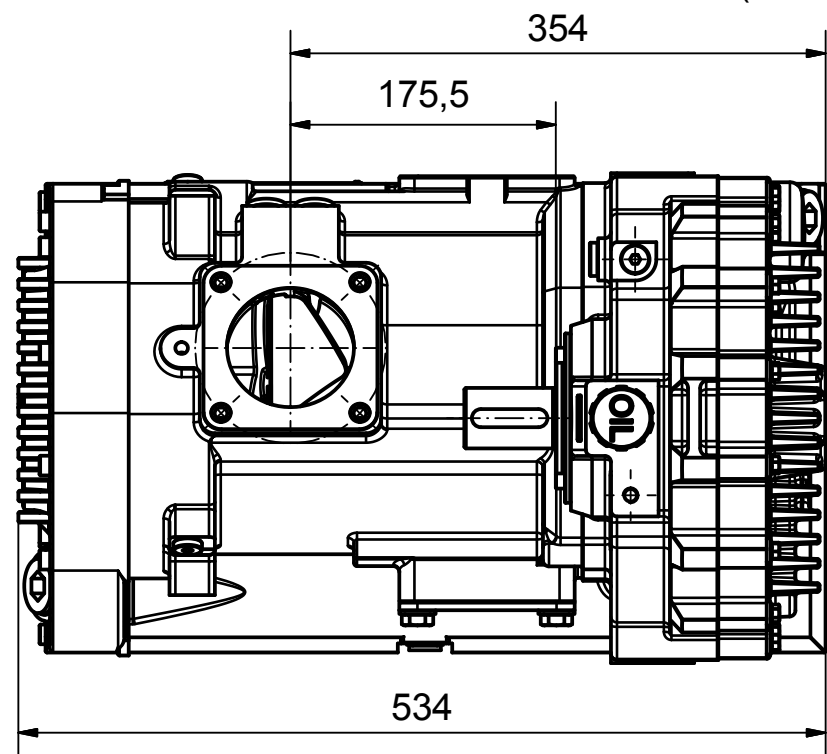
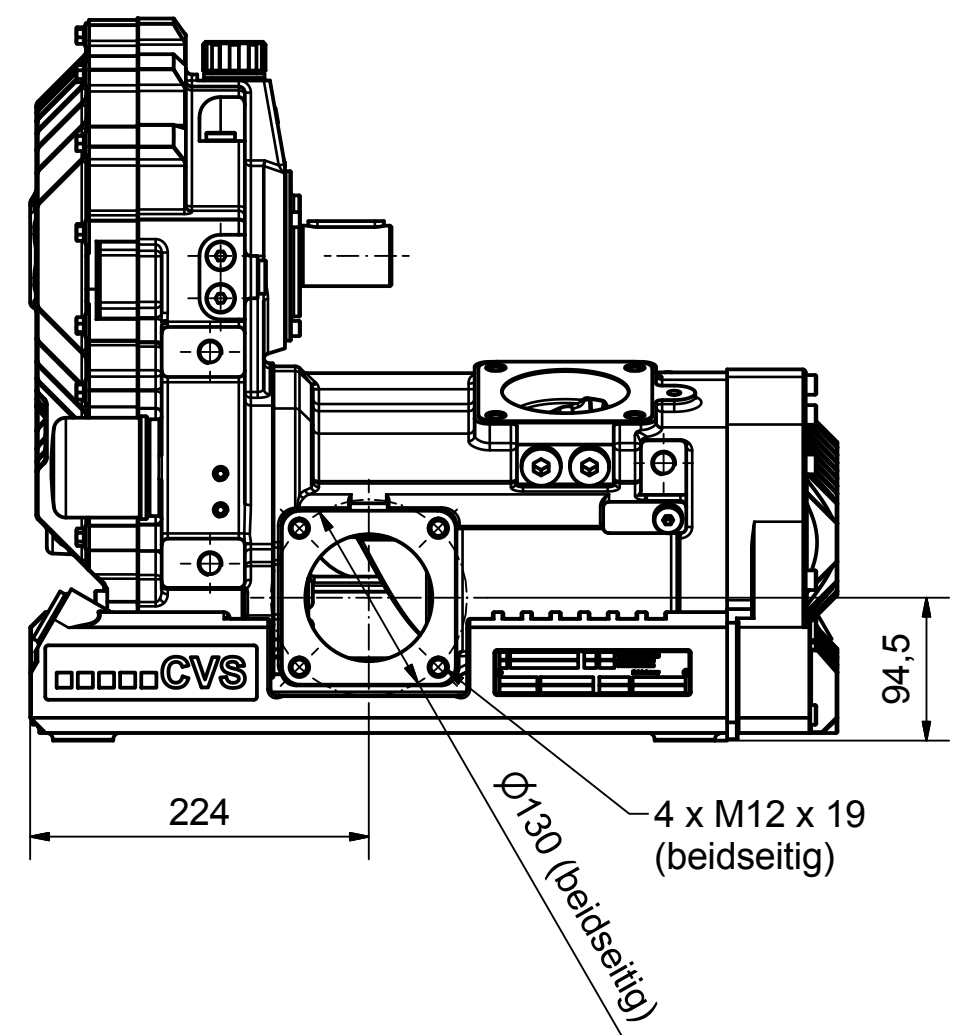
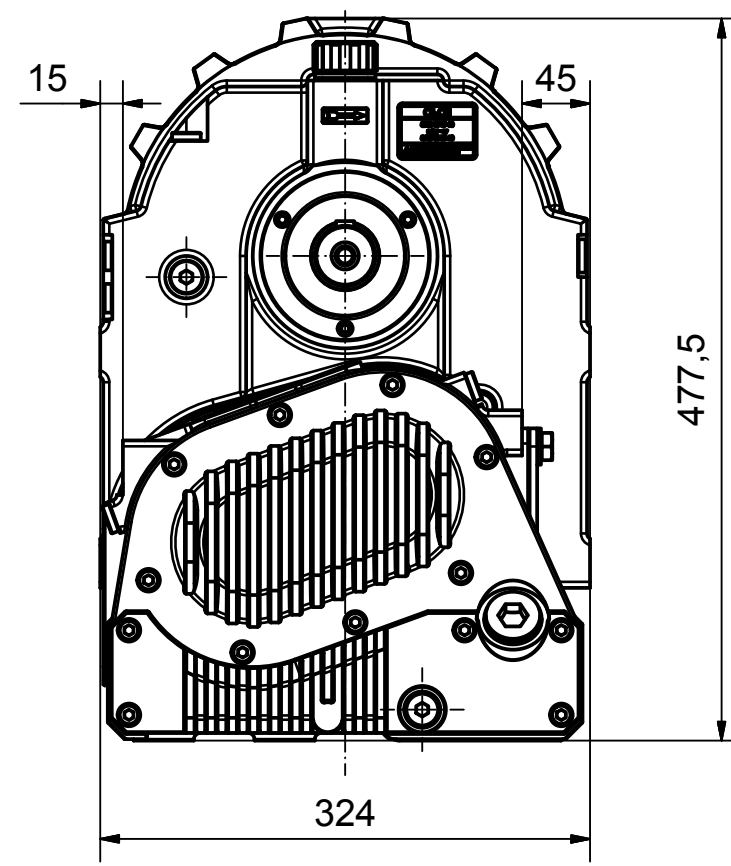
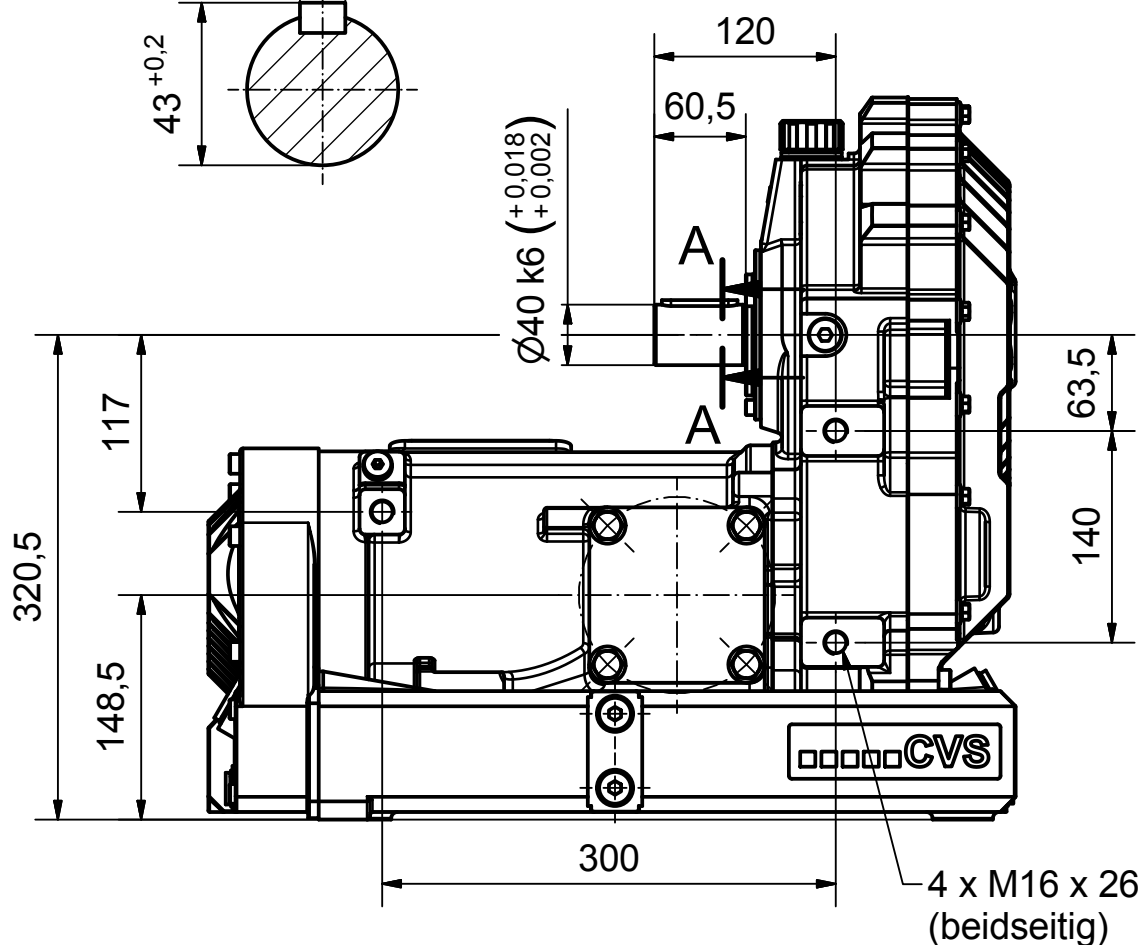

X (1:5)

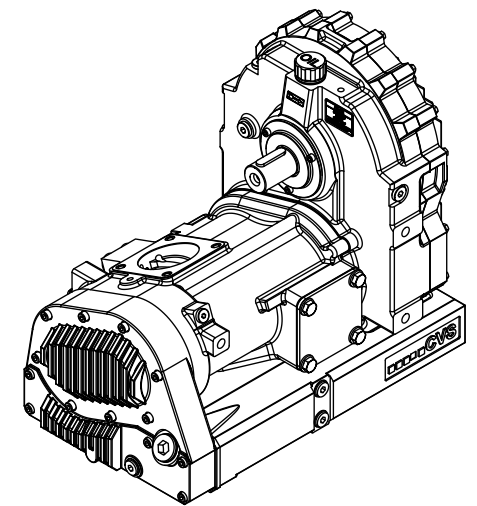
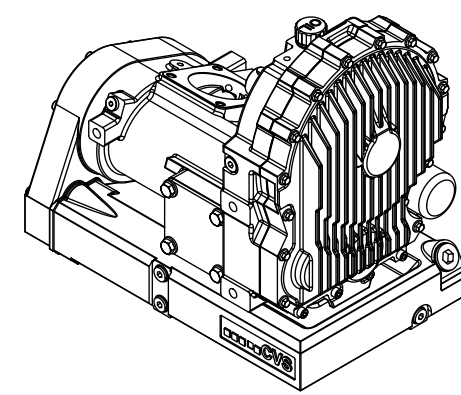
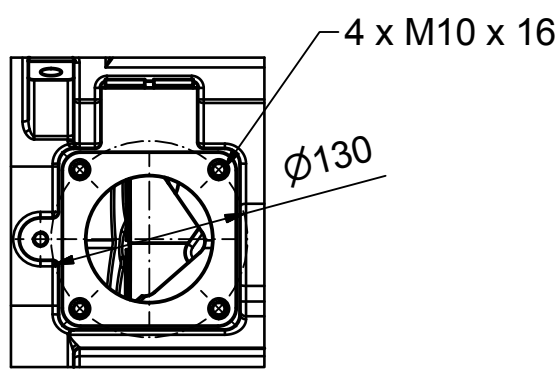

Erstellt: Issued:	19.12.2017 M.Waßmer	Geprüft: Checked:	12.11.2018 Wagner	Genehmigt: Approved:	12.11.2018 Wagner
Ersatz für: Replaces:		Ersetzt durch: Replaced by:		Maßstab: Scale:	1:5
				Sprache: Language:	

CVS engineering GmbH, Großmattstraße 14, D-79618 Rheinfelden
Tel. +49-7623-71741-0 Fax. +49-7623-71741-90

Schutzvermerk
ISO 16016 beachten